

## 可逆马达 Reversible Motor 40-60W



### 马达特性表 Specifications of motor

马达型号 Motor Model No.		出力 Force W	周波数 Peripheral Wave No Hz	电压 Voltage V	电流 Current A	启动转矩 Start Turning Moment gcm	定格 Rating		容量 Capacity μF	耐电压 Resistance Voltage	齿轮型号 Gear Model No		
圆柱出力轴 Cylindrical Output Shaft	小齿切出力轴 Pinion Cut Output Shaft						转矩 Turning Moment gcm	回转速数 Revolving No rpm			培林(轴承) Pairing Bearing	中间齿轮 Middle Gear	
可逆马达 Reversible Motor	5RK40A-A	5RK40GN/GU-A	40	50	110	0.90	3000	3000	1300	12	250	5GN/GU-K	5GN10X
				60	110	0.82	2500	2515	1550				
	5RK40A-C	5RK40GN/GU-C	40	50	220	0.45	3000	3000	1300	3	500	5GN/GU-K	5GN10X
				60	220	0.41	2500	2515	1550				
	5RK60A-A	5RK60GN/GU-A	60	50	110	1.10	4500	4500	1300	15	250	5GN/GU-K	5GN10X
				60	110	1.0	3770	3770	1550				
	5RK60A-C	5RK60GN/GU-C	60	50	220	0.55	4500	4500	1300	4	500	5GN/GU-K	5GN10X
				60	220	0.50	3770	3770	1550				

### 外型尺寸: External dimension

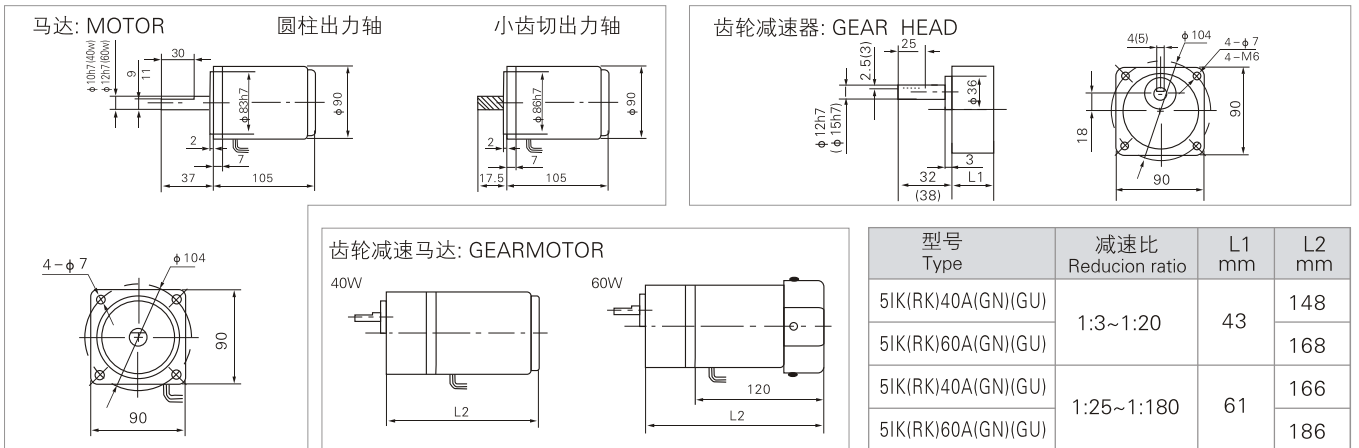

### 扭距表: Gear Head-Torque Table(Kg-cm)

(Kg/cm × 9.8 ÷ 100) = N · M (牛顿 · 米)

同步转速: r/min	500	300	200	150	120	100	75	60	50	30	20	15	10	7.5	6	5	3	
减速比: Gear reduction ratio	50Hz	3	5	7.5	10	12.5	15	20	25	30	50	75	100	150	200	250	300	500
	60Hz	3.6	6	9		15	18		30	36	60	90	120	180	300	360	600	
允许负载 Permissible load	40W	Kg · cm	6.7	11	16	21.3	28	33	42	54	65	108	150	150	150	150	150	150
	60W	Kg · cm	10	16	24	32	40	48	64	77	93	150	150	150	150	150	150	150

表列数字是根据马达同步运转的转速,在额定负载情况下实际输出转速为同步运转转速的80%~90%。浅灰色表示输出轴运转方向与马达转向相同,白色栏表示输出方向与马达轴转向相反。

Note: Speed figures are based on synchronous speed, The actual output speed, under rated torque conditions, is about 10~20% less than synchronous speed, a grey background indicates output shaft of geared motor rotates in the same direction as output shaft of motor. A white background indicates rotation in the opposite direction.